

13 series is designed in strict accordance with the requirements of the mobile machinery industry. Its compact shape can be fully integrated with the hydraulic cylinder with limited head space. The high versatile IP68 profile housing offers full protection for use in harsh environments with high contamination and presence of dust. If the hydraulic cylinder is used with a special connector, the protection level is up to IP69K. Vibration and shock rating are also high-level 25g / 10-2000Hz and 100g (single shock).

It adopts the non-contact magnet-rostrictive measuring technology for precise, accurate, and absolute measurement. The non-contact feature provides exceptional ease of installation and guarantees almost unlimited mechanical life expectancy.



Specifications

Order Code	13 M / L
Output	Voltage / Current
Measurement Type	Linear displacement
Resolution	<500mm ±0.10mm, 700mm ±0.18mm, 1000mm ±0.24mm 1250mm ±0.30mm, 1750mm ±0.42mm,
Repeatability	< ±0.005% of full scale
Non-Linearity	< ±0.04% of full scale (minimum ±100µm for 60mm damping zone) < ±0.08% of full scale (for 36.5mm damping zone)
Input Voltage	+12V / +24Vdc
Input Protection	Polarity protection up to -30Vdc, Over voltage protection up to 36Vdc
Power Consumption	1W
Dielectric Strength	500Vdc (DC ground to machine ground)
Operation Temp.	-40 to 85°C, Humidity 90% non-condensing
Sealing	IP 68 (IP 69K when installed inside a cylinder with M12x1 connection type)
Vibration Rating	25g / 10-2000Hz / IEC standard 68-2-6
Shock Rating	100g single hit per IEC standard 68-2-27
EMC	Emission EN 61000-6-3, Immunity EN 61000-6-2, EN 61000-4-2/3/4/6
Pressure Rating	350 bar / 530 bar peak
Material	Stainless Steel

Order Code

1 3 X X X X X X X X X X X X X X

Model

M = stroke 25 to 2500mm
L = stroke 2500 to 3800mm

Output

011 = 0.25 - 4.75V 015 = 0.5 - 10V
012 = 0.5 - 4.5V 101 = 4 - 20mA
013 = 4.75 - 0.25V 104 = 20 - 4mA
014 = 4.5 - 0.5V

Connection Type

N__A = 4 single wires (20AWG)
N__E = 4 single wires , M12x1 IP69K,4pin (pin assignment 2-3-4)
N__G = 4 single wires , M12x1 IP69K,4pin (pin assignment 1-3-4)
N__H = 4 single wires , M12x1 IP69K,4pin (pin assignment 1-2-3)
Ex. : 06 = 60mm wire length
 25 = 250mm wire length
T__A = integral PUR shielded cable, pigtail for wire termination
Ex. : 10 = 1.0 meter cable length (0.5 meter mini.)
 35 = 3.5 meter cable length

Sensor Styles

1 = 10mm dia. rod, damping zone 60mm
2 = 10mm dia. rod, damping zone 36.5mm
3 = 7mm dia. rod, damping zone 60mm (for stroke <1300mm)

Magnet Type

1 = Outer dia. 33mm, inner dia. 13.5 ring magnet
2 = Outer dia. 25.4mm, inner dia. 13.5 ring magnet
3 = Outer dia. 17.4mm, inner dia. 13.5 ring magnet

Stroke Length (mm)

0075, 0100, 0125, 0150, 0175, 0200, 0225
0250, 0275, 0300, 0325, 0350, 0375, 0400
0425, 0450 (25mm increment after)

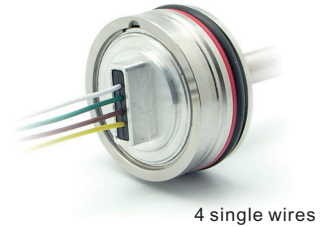

4 single wires



IP69K M12x1

Pin Assignments

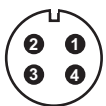

4 pin M12 A model
(View toward sensor pins)

	Color	N__E
1	Yellow	N.C.
2	Brown	12/24 Vdc
3	White	0 Vdc
4	Green	Output

	Color	N__G
1	Brown	12/24 Vdc
2	Yellow	N.C.
3	White	0 Vdc
4	Green	Output

	Color	N__H
1	Brown	12/24 Vdc
2	Green	Output
3	White	0 Vdc
4	Yellow	N.C.

Cable Assignments

Color	N__A
Brown	12/24 Vdc
Green	Output
Yellow	N.C.
White	0 Vdc

Color	T__A
Red	12/24 Vdc
Green	Output
Yellow	N.C.
Black	0 Vdc

Specifications

Order Code	13 M / L
Output	Direct CANopen or CAN J1939
Measurement Type	Linear displacement
Resolution	<500mm ±0.10mm, 700mm ±0.18mm, 1000mm ±0.24mm 1250mm ±0.30mm, 1750mm ±0.42mm,
Repeatability	< ±0.005% of full scale
Non-Linearity	< ±0.04% of full scale (minimum ±100µm for 60mm damping zone) < ±0.08% of full scale (for 36.5mm damping zone)
Input Voltage	+12V / +24Vdc
Input Protection	Polarity protection up to -30Vdc, Over voltage protection up to 36Vdc
Power Consumption	1W
Dielectric Strength	500Vdc (DC ground to machine ground)
Operation Temp.	-40 to 85°C, Humidity 90% non-condensing
Sealing	IP 68 (IP 69K when installed inside a cylinder with M12x1 connection type)
Vibration Rating	25g / 10-2000Hz / IEC standard 68-2-6
Shock Rating	100g single hit per IEC standard 68-2-27
EMC	Emission EN 61000-6-3, Immunity EN 61000-6-2, EN 61000-4-2/3/4/6
Pressure Rating	350 bar / 530 bar peak
Material	Stainless Steel

Pin Assignments

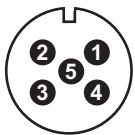

5 pin M12 A model
(View toward sensor pins)

	Color	N__F
1	N.C.	N.C.
2	Brown	12/24 Vdc
3	White	0 Vdc
4	Yellow	CAN High
5	Green	CAN Low

Cable Assignments

Color	N__A
Brown	12/24 Vdc
Green	CAN Low
Yellow	CAN High
White	0 Vdc

Color	T__A
Red	12/24 Vdc
Green	CAN Low
Yellow	CAN High
Black	0 Vdc



IP69K M12x1

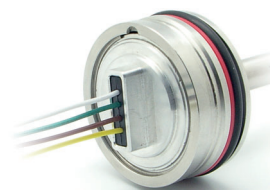

4 single wires

mobile hydraulic technology ...



Order Code

1 3 X X X X X X X X X X X X X X X X X X

Model

M = stroke 25 to 2500mm
L = stroke 2500 to 3800mm

Output

C01 = CANopen
J01 = SAE J1939

Baud Rate

0 = 1000 kBit/s 4 = 125 kBit/s
1 = 800 kBit/s 6 = 50 kBit/s
2 = 500 kBit/s 7 = 20 kBit/s
3 = 250 kBit/s 8 = 10 kBit/s

Node-ID

CANopen : hex 01 to 7F (default 7F)
SAE J1939 : hex 01 to FD (default FD)

Connection Type

N__A = pigtail (stripped conductors) no termination (20AWG)
N__F = 4 single wires , M12x1 IP69K,5pin (pin assignment 2-3-4-5)
 Ex. : 06 = 60mm wire length
 25 = 250mm wire length
T__A = 4 wires integral PUR shielded cable, pigtailed
 Ex. : 10 = 1.0 meter cable length (0.5 meter mini.)
 35 = 3.5 meter cable length

Sensor Styles

1 = 10mm dia. rod, damping zone 60mm
2 = 10mm dia. rod, damping zone 36.5mm
3 = 7mm dia. rod, damping zone 60mm (for stroke <1300mm)

Magnet Type

1 = Outer dia. 33mm, inner dia. 13.5 ring magnet
2 = Outer dia. 25.4mm, inner dia. 13.5 ring magnet
3 = Outer dia. 17.4mm, inner dia. 13.5 ring magnet

Stroke Length (mm)

0075, 0100, 0125, 0150, 0175, 0200, 0225
0250, 0275, 0300, 0325, 0350, 0375, 0400
0425, 0450 (25mm increment after)



Installation Dimensions

M model

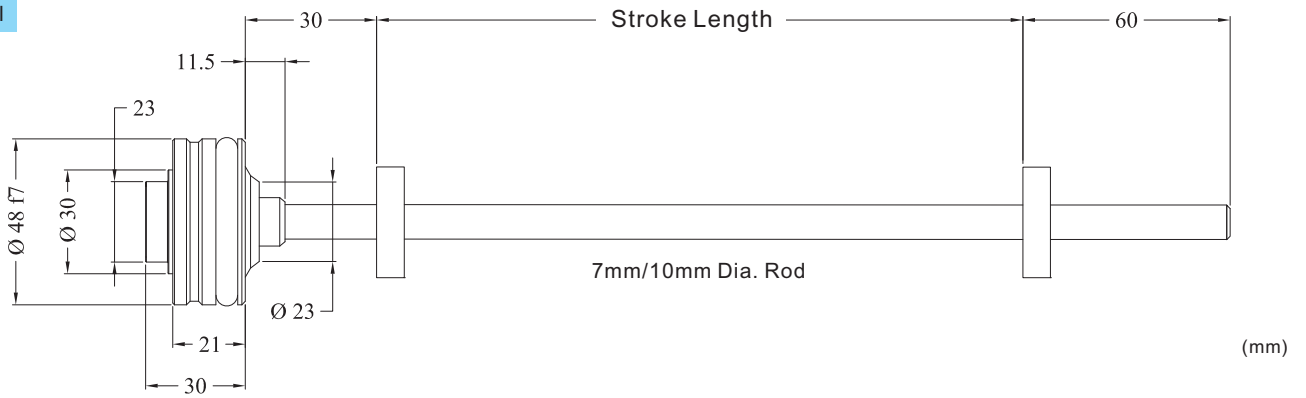

L model

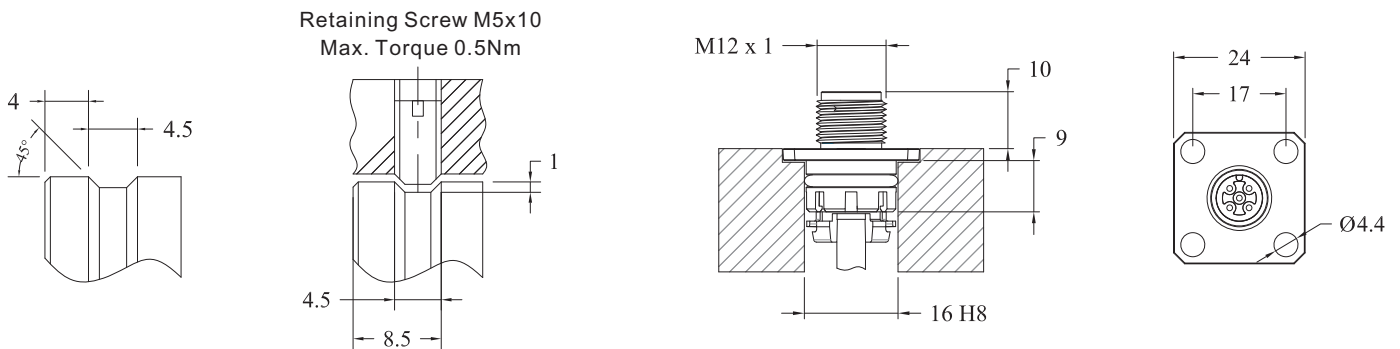
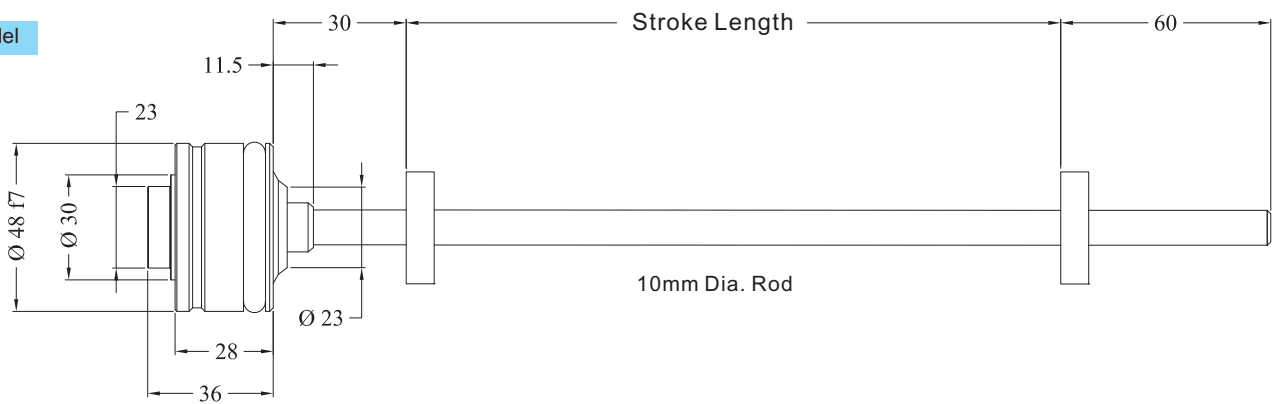

Installation

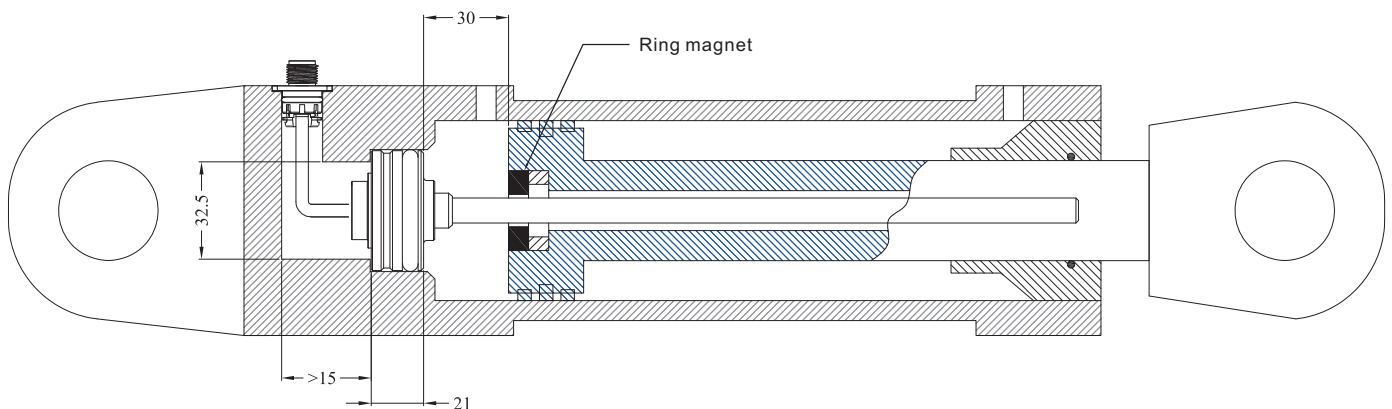

Discription
Order Code

Outer Dia. 17.4 mm ring
17 00 951 025

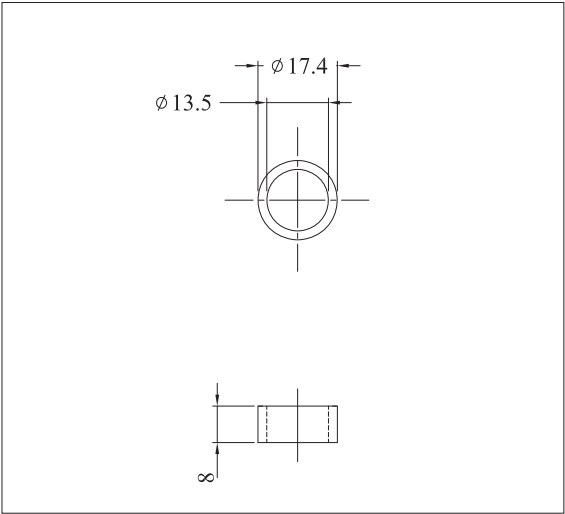

Outer Dia. 25.4mm ring
17 00 951 023

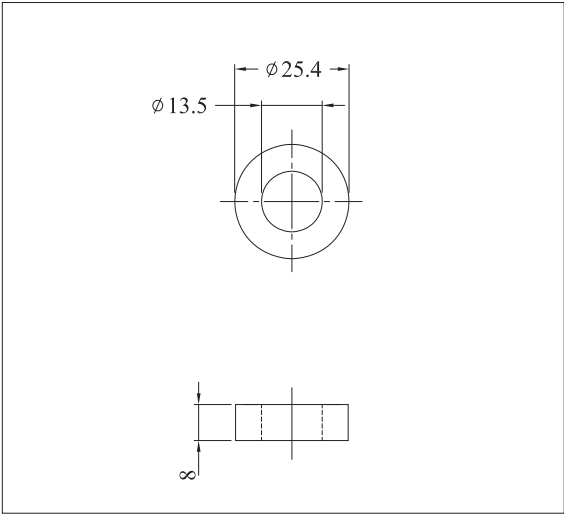

Material
Weight

Plastic
~4g

Plastic
~8g

Discription
Order Code

Outer Dia. 33mm ring
17 00 951 001

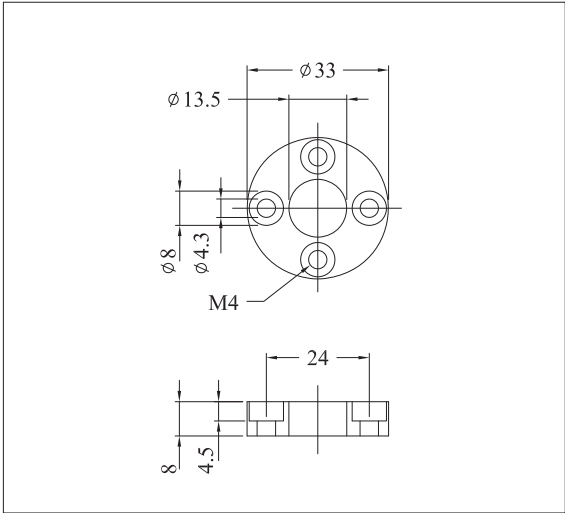

Material
Weight

Plastic
~8g

Discription
Order Code
Material

Dia. 33mm Spacer
17 00 951 002
Plastic

Remark

- 1) Use a non-ferrous circlip to fastern the magnet.
- 2) Minimum drilling for a 10mm rod should be 13.5mm.
- 3) No less than 3mm clearance between the end of the sensor rod and the bottom of the rod bore at full retraction.

